

ASSEMBLY INSTRUCTIONS

82008-XXX

Step 1

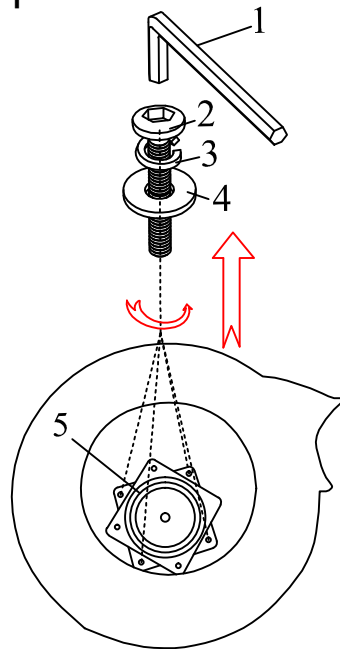

Step 2

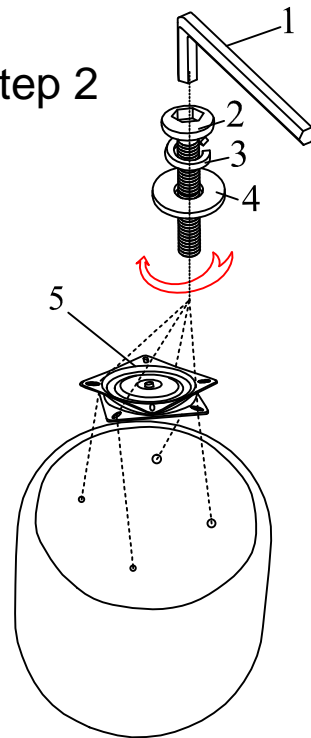

Step 3

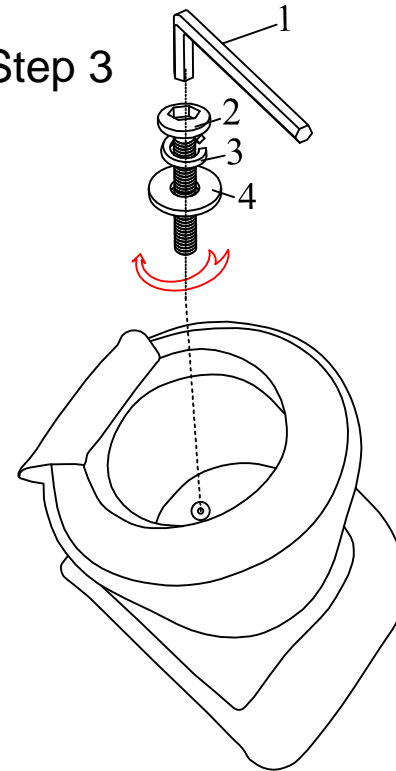



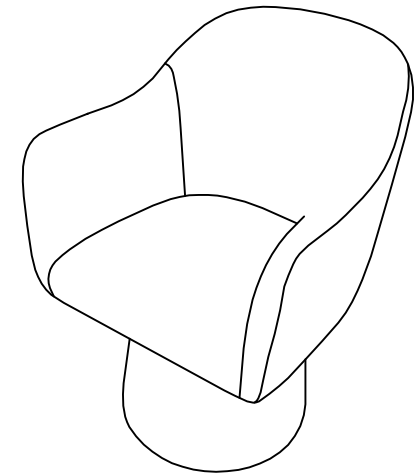

Finish



Move to the hole position to be connected with screw hole then tighten by screw

Hardware

1		"L" Wrench	1pc
2		Bolt 6*25mm	8pcs
3		Spring Washer	8pcs
4		Flat Washer	8pcs
5		Turnplate 6.75 inch	1pc